

OVERHEAD DEHUMIDIFIER

INNO-225pOHDh

User Manual

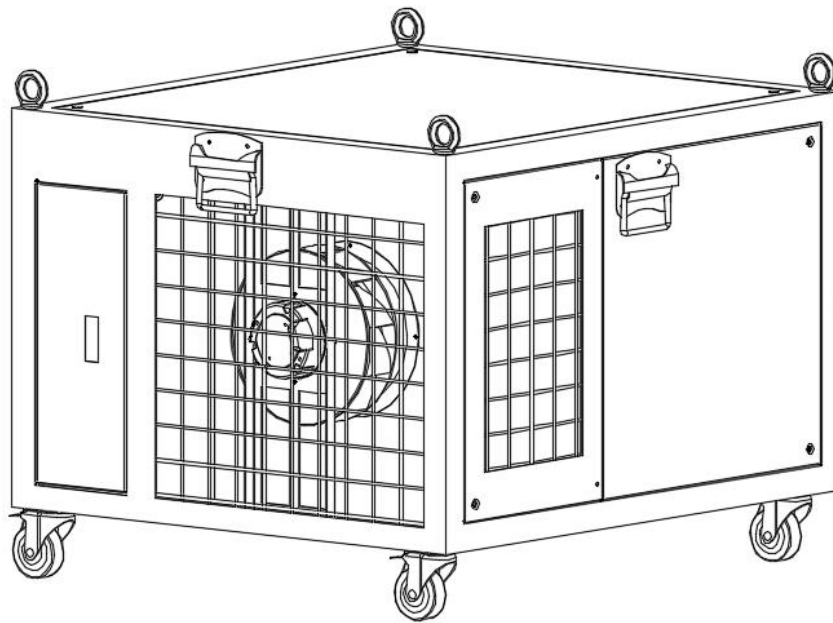

The installation and maintenance of this unit must be performed by a professional technician who holds a professional qualification certificate that meets the local installation and maintenance requirements and who has experience in the installation and maintenance of this model. Unauthorized installation or maintenance of the equipment is not permitted.

Please read this manual carefully before installation, use or maintenance.

CONTENTS

1. Features	2
2. Components	3
3. Installation	3
4. Maintenance	5
5. Troubleshooting	5
6. Operation	8
7. Wiring Diagram	11
8. Specifications	11
9. Drawing	12

FEATURES

Overhead type dehumidifier is powered by electricity, and through the principle of freezing and dehumidifying, the indoor air is dehumidified and processed, and sent to the required dehumidified room.

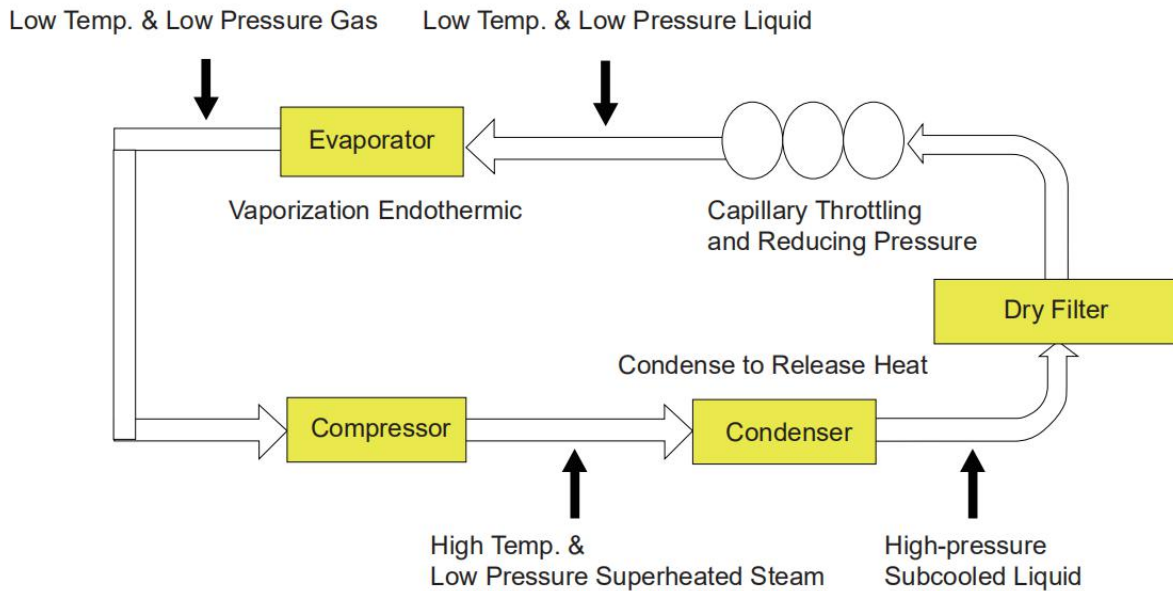

Energy-saving and high efficiency

As the unit adopts the principle of condensing heat recovery to re-temperature the air after dehumidification, it reduces the unit's heating energy consumption and improves the operating efficiency of the whole unit.

Save indoor installation space

The unit can be installed by lifting, thus saving the installation space of the indoor dehumidifier.

Easy maintenance

The flexible and simple design makes maintenance extremely easy. The inspection door plate adopts the latch structure, so the internal parts are easy to be serviced.

Reliable quality and long service life

Large brand compressor and high-quality accessories are selected and the compressor operates in a better environment, resulting in longer working life.

Excellent air supply status

Since the unit is connected to each room in room through ducts, all rooms in the room can get high-quality dry air.

COMPONENTS

Fan section

The fan section consists of the impeller/worm housing assembly of the fan and the fan motor. There is a thermal insulation layer between the water collection tray and the box of the unit to avoid condensation of the box.

The fan of the unit is a high-efficiency centrifugal fan, and the noise of the fan motor is much lower. The fan bracket and the fixed plate are bolted together for easy disassembly. All centrifugal fan impellers are tested for balance, thus minimizing vibration.

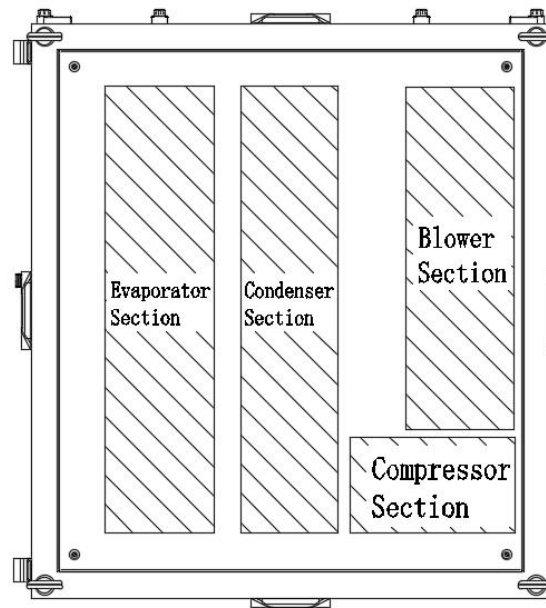

INSTALLATION

1. Ceiling unit installation: (see Figure 1)

The unit is designed to be suspended from the ceiling. Make sure the top hanging parts have enough strength to bear the weight of the unit when it is suspended (see the nameplate of the unit for the weight of the unit). Set the position of the hanging rod, check whether the hanging plate is reliable and check whether it is aligned with the installation hole of the unit to avoid the rod from touching the panel. As shown in Figure 1. The lugs can be fitted with a threaded boom of ϕ 8mm or more. The boom is equipped with a spring shock absorption system, and the unit should be slightly inclined to the condensate discharge port (1% slope) when it is installed.

Figure 1: Installation

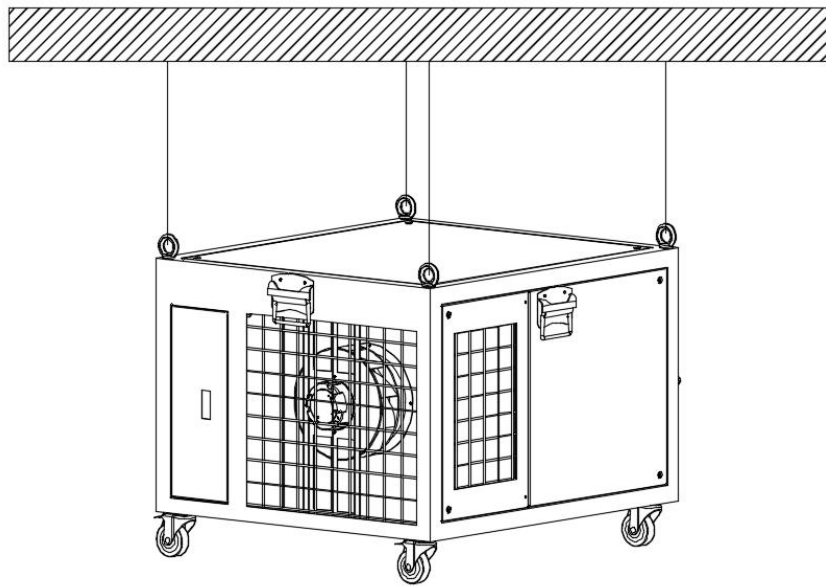

2. Condensate discharge: (see Figure 3)

When installing the condensate pipe or hose, there must be installed water storage bend at least 1 inch (25mm) height on the condensate pipe, such as static pressure greater than 250Pa storage bend height should increase (1mmH₂O = 9.8Pa). All condensate pipes should be sloped from the unit to the drainage point for gravity discharge. The requirements of relevant local regulations should be followed.

Note: After the unit is installed, when commissioning, open the access panel and inject a little water into the unit's water tray to form a certain water seal.

Figure 2: Drainage

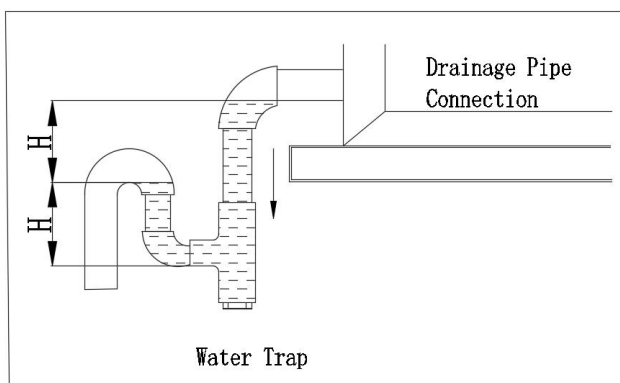

3. Air duct

The diameter of the supply and return air duct is greater than or equal to the unit air outlet flange size to reduce the noise of the supply and return air system. Both the return air duct and the exhaust air duct should be lined with sound-deadening cotton, and there should be at least one 90° bend before leading to the first outlet grille. To reduce the noise coming from the unit through the air duct, it is recommended to install a section of soft air duct.

To ensure the airflow of the unit, the correct installation of the duct is essential. It is recommended that there should be no bend or connection in the smallest straight section of the exhaust air outlet. Otherwise, the air volume of the fan will be greatly reduced.

MAINTENANCE

1. Start up:

After the unit is installed, the air duct, condensate discharge pipe and power supply line are connected, and all internal wiring and wiring with external control devices are checked for correctness, it is ready to start.

2. Air filter.

The unit must never operate without a filter. The filter should be cleaned at least once every three months, or more frequently in a dirty environment. Because a dirty filter will cause the unit to operate inefficiently.

3. Air coils and fan impellers.

The air coil and fan impeller should be inspected at least once a year. If needed, they should be cleaned in due time.

4. Compressor.

The dehumidifying unit is designed with various protection switches that can protect the refrigerant system of the unit. When the pressure of refrigerant is too high or too low, these protection switches will automatically shut down the compressor.

WARNING 

Before dismantling the unit box access panel, make sure to disconnect the power of the unit!

TROUBLESHOOTING

Problem	Cause	Solution
Unit vibration	Exhaust or suction ducts hitting metal surfaces	Bend the exhaust pipe or suction pipe, adjust the gap so that they do not touch each other
	Fan impeller is twisted or loose	Tighten the impeller or replace the impeller
	The impeller motor is not centered, the shaft is bent or loosely installed	Check the alignment and install firmly. If the shaft is bent, replace the motor
Poor condensate drainage	Improper level or slope of the unit	Adjust the slope of the unit
	Clogged condensate drainage pipe	Clean up the condensate line
Fan noise	Impeller collision	Check the impeller and adjust the gap
	Twisted impeller	Check and replace impeller
	Loose impeller and shaft	Check and reinforce
Unit running noise	Compressor	Broken compressor valve or loose discharge pipe will cause excessive noise. Replace it.
	Wind or other noise	Small air ducts causing high velocity airflow will cause noise. High water flow through the condenser will cause water flow noise The use of throttling measures to ensure the appropriate water flow

Unit running but not dehumidifying	Open filter clogged	Check the filter, if found too dirty, should be cleaned or replaced
	Compressor failure or refrigerant leakage	If the compressor is running and the evaporator is not cooling, it indicates that the compressor is malfunctioning or the refrigerant is leaking
Evaporator frosting	Clogged air filter	Check the filter, if found too dirty, should be cleaned or replaced
	Blower motor tripped due to overload	Check the fan motor overheating situation
	Unit operating at a low room temperature	If the room temperature is lower than 12.8 °C , the evaporator may freeze
High pressure protection	Discharge pressure is too high	The condenser is blocked, the inlet air temperature is too high, the air volume suddenly becomes small
	Refrigerant charge	Refrigerant is overcharged, pump out some refrigerant or empty the refrigerant and recharge it according to the specified amount
	High pressure switch failure	Switch cannot be reset or damaged, replace it
Low pressure protection	Suction pressure too low	The evaporator is blocked, the inlet air temperature is too low, and the air volume suddenly becomes small.
	Refrigerant quantity	The amount of refrigerant is too low, find out the leakage point and repair, evacuate and recharge the refrigerant
	Low pressure switch failure	Low pressure switch failure, replace it
Insufficient dehumidification capacity	Unit too small	Recalculate the amount of humidity produced in the air-conditioning room to ensure the air volume through the evaporator and condenser.
	Conditioned air leaking out	Check whether the air duct is leaking or outdoor air is introduced through the door or window
	Humidity sensor	Improper sensor installation
	Air volume	The air volume is too small or unevenly distributed, check the size of the air duct, air filter, filter should be checked every three months, such as too dirty should be cleaned or replaced.
	Charging volume	Insufficient filling volume, so that it can not run
	Fan reversal	Reverse the lead of the motor capacitor
	Compressor	Check the defective compressor, such as low discharge pressure. The suction pressure is too high, the compressor can't pressurize normally, replace it.
	Operating pressure	Operating pressure is not normal
Refrigerant system	Check filter and capillary tube for possible blockage of refrigerant flow, refrigerant system may be subject to moisture non-condensable or debris invasion. Dehydrate the system, evacuate and re-charge the refrigerant.	

OPERATION

Control System

The microcomputer control system of the unit has the following functions.

- Random start relay
- Protection against frequent compressor start/stop
- High and low-pressure protection
- Motor thermal overload protection
- Filter cleaning reminder (optional)
- Self-start for incoming calls

Note: The function to prevent frequent compressor start/stop prevents the compressor from restarting within 3 minutes after stopping operation.

Control Panel Guide

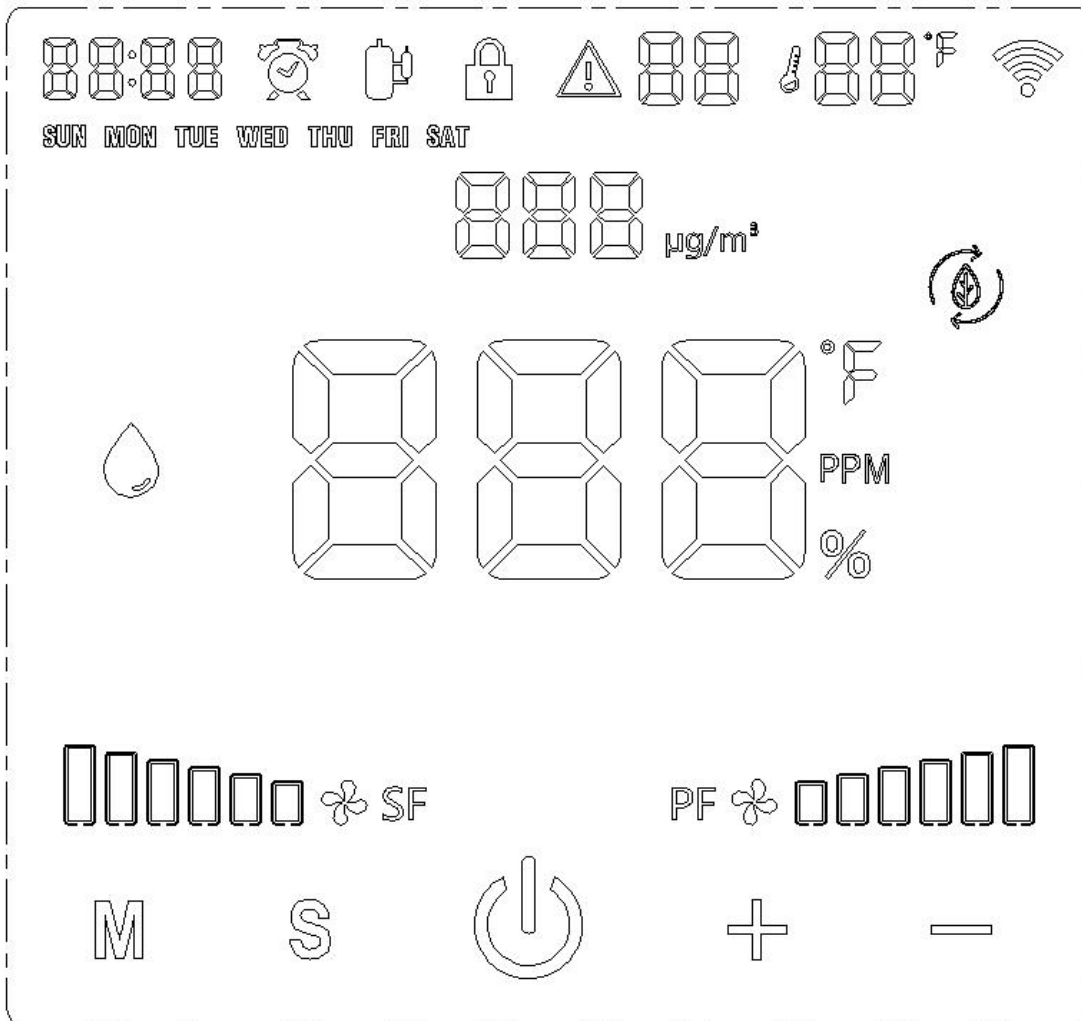

M Mode

S Fan speed



Power button

+ Add

- Minus

On/Off

Press  to switch the machine on or off.

Mode

Press to choose Dehumidifying or Ventilating mode.

Fan speed

By pressing the **S** button, you can set the fan speed. The fan speed conversion order: 1 gear-2 gear-3 gear-4 gear-5 gear-6 gear-1 gear

Only available in the ventilation mode. The fan speed can not be adjusted under dehumidifying mode.

Lock function

Press the **+** and **-** keys simultaneously for 5 seconds to lock or unlock the unit. When the unit is locked, the

screen displays  .

Humidity setting and display

Humidity setting can be done through the **+/-** keys.

When pressing any **+/-** key will activate the humidity setting function, then it will flash and display the

humidity setting value, then change the humidity setting value by **+/-** key, such as exiting the humidity setting mode automatically after 5 seconds of no-operation.

Time and Timer Setting

Under the homepage, long-press the **S** for 5 seconds to enter the time setting menu, then short press the **S** to switch menu items, menu switching order: time setting - timer boot setting - timer off setting - time setting. Under the homepage, if any timer on/off is set, the alarm clock symbol is displayed.

1) Time Setting

Press and hold the S button for 5 seconds to enter the time setting menu, and the real-time flashes on the display. At this time, press M to set the current week, press + to set the current hour, press - to set the current minute. After setting, press and hold the S button for 5 seconds to exit and update the set time. You can also wait until the timer is set and then press and hold the S key for 5 seconds to exit and save. If there is no operation for 30 seconds to exit automatically, the setting is invalid.

2) Timer on setting

In the time setting menu state, by short pressing the **S** to enter the timer start setting menu, the time and on symbol flashing at the same time. At this time, press the **M** to select the week of timer on, press the **+** to

select the hour of timer on, press the - to select the minute of timer on. After setting, press and hold the **S** for 5 seconds to exit and save the timer start time. You can also wait for the timer to finish all set and then long-press the **S** for 5 seconds to exit and save. If there is no operation for 30 seconds, then it will exit automatically, and the setting is invalid.

3) Timer off setting

In the timer-on menu, enter the timer-off setting menu by short pressing the **S**, and the time and of symbols are displayed flashing at the same time. At this time, press **M** to select the week of timer shutdown, press **+** to select the hour of timer shutdown, press - to select the minute of timer shutdown. After setting, press and hold the **S** for 5 seconds to exit and save the timer off time. You can also wait for the timer to finish all set and then long-press the **S** for 5 seconds to exit and save. If there is no operation for 30 seconds, then it will exit automatically, and the setting is invalid.

Unit address setting

Under the homepage, press and hold the S key and + key for 5 seconds to enter the unit address setting menu. The unit symbol and unit address are displayed flashing. The unit address can be set by pressing the +/- key. After setting, press and hold S and + keys to exit and send the address to the mainboard for saving. If there is no operation for 30 seconds, it will exit automatically, and the setting is invalid.

Set the filter level and clear the filter time

Under the homepage, press and hold the **M** for 5 seconds to enter, at this time, the user needs to enter the password. The time zone displays 0000 and the activated password bit is flashing. Set the activated password bit by pressing the **+/-**, and select the password bit by pressing the **M**. After entering the correct password

1015, press the  to enter the Set Filter Stall menu. By pressing the **+/-** you can set it in the range of 1-3.

After the setting is completed, press and hold the **M** for 5 seconds to exit. If there is no operation for 30 seconds, it will exit automatically, and the setting is invalid.

After entering password 3373 in the password input status, press the  to clear the filter time.

Fault clear

Each time the user shuts down, a fault clear command is automatically sent to the mainboard, and the recoverable fault will be cleared.

System parameter inquiry

Under the homepage, press and hold the S key and - key for 5 seconds to enter the system parameter query menu. Select the parameter item you want to view by +/- key.

Code	Time zone	Remark
C0	Return air humidity	
C1	Return air temperature	
C2	Inner tray 1 temperature	
C3	Inner tray 2 temperature	
C4	Filter running time	Actual value divided by 10

C5	Fan speed	
C6	Machine type	
C7	Mainboard program version number	
C8	In-line control program version number	
C9	Compressor 1 status	1=on; 0=off;
CA	Compressor 2 status	1=on; 0=off;
CB	Fan status	1=on; 0=off;
CC	Water pump status	1=on; 0=off;
CD	High-pressure switch 1 status	1=on; 0=off;
CE	Low-pressure switch 1 status	1=on; 0=off;
CF	High-pressure switch 2 status	1=on; 0=off;
d0	Low-pressure switch 2 status	1=on; 0=off;
d1	Water level switch status	1=on; 0=off;

If there is no operation for 120 seconds, it will exit automatically.

Fault display

If a fault occurs in the unit, the line control flashes the fault code in the unit number area. If multiple faults occur at the same time, each fault code is displayed in turn. For recoverable faults, it can be cleared by power off. The filter alarm needs to be cleared by entering the menu.

Code	Fault information
E1	
E2	
E3	Return air humidity fault
E4	Return air temperature fault
E5	Inner tray 1 temperature fault
E6	Inner tray 2 temperature fault
E7	Compressor 1 high-pressure fault
E8	Compressor 1 low-pressure fault
E9	
EA	Water level switch protection
EB	Compressor 2 high-pressure fault
EC	Compressor 2 low-pressure fault
ED	Filter alarm (filter symbol flashes and fault code is displayed when there is an alarm)
EE	
EF	

WIRING DIAGRAM

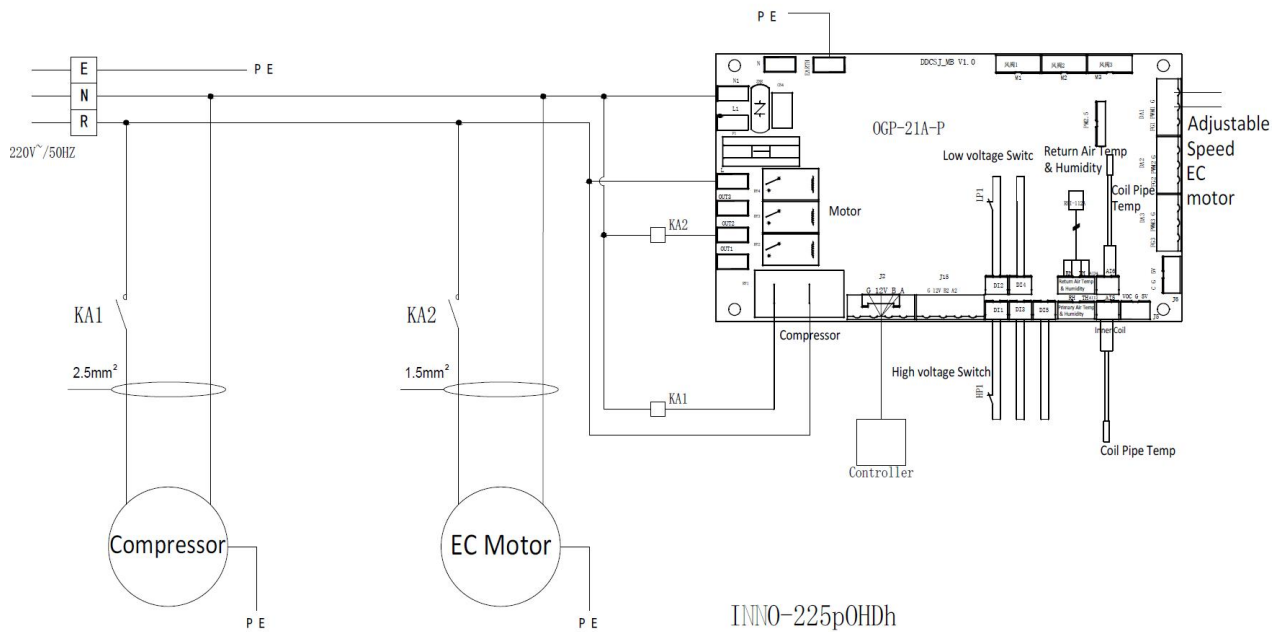

SPECIFICATIONS

Unit	INNO-225pOHDh
Power Supply	AC 220V/60Hz
Power Consumption(80°F, 60%RH)	1385W
Rated Current(80°F, 60%RH)	6.4A
Dehumidify Capacity(80°F, 60%RH)	201pints/day(95L/day)
Energy Factor	2.86 L/kWh
Efficiency	6.0 Pints/kWh
Drainage	Tube Continuously Drainage
Air Circulation	529CFM
Noise Level	<55dB(A)
Refrigerant	R410A
Working Temp.	13°C~35°C(55.4°F-95°F)
Control Type	Remote control
Auto Defrost	Yes
Dimensions(L*W*H)	880*792*727.3mm(34.6'' *31.2''*28.6'')
Net Weight	80kg(176 lbs.)

Note: Standard working condition: indoor unit inlet air dry bulb temperature is 35 °C , relative humidity 60%; outdoor unit inlet air dry bulb temperature is 35 °C . Power supply voltage fluctuation within ±10%.

DRAWINGS

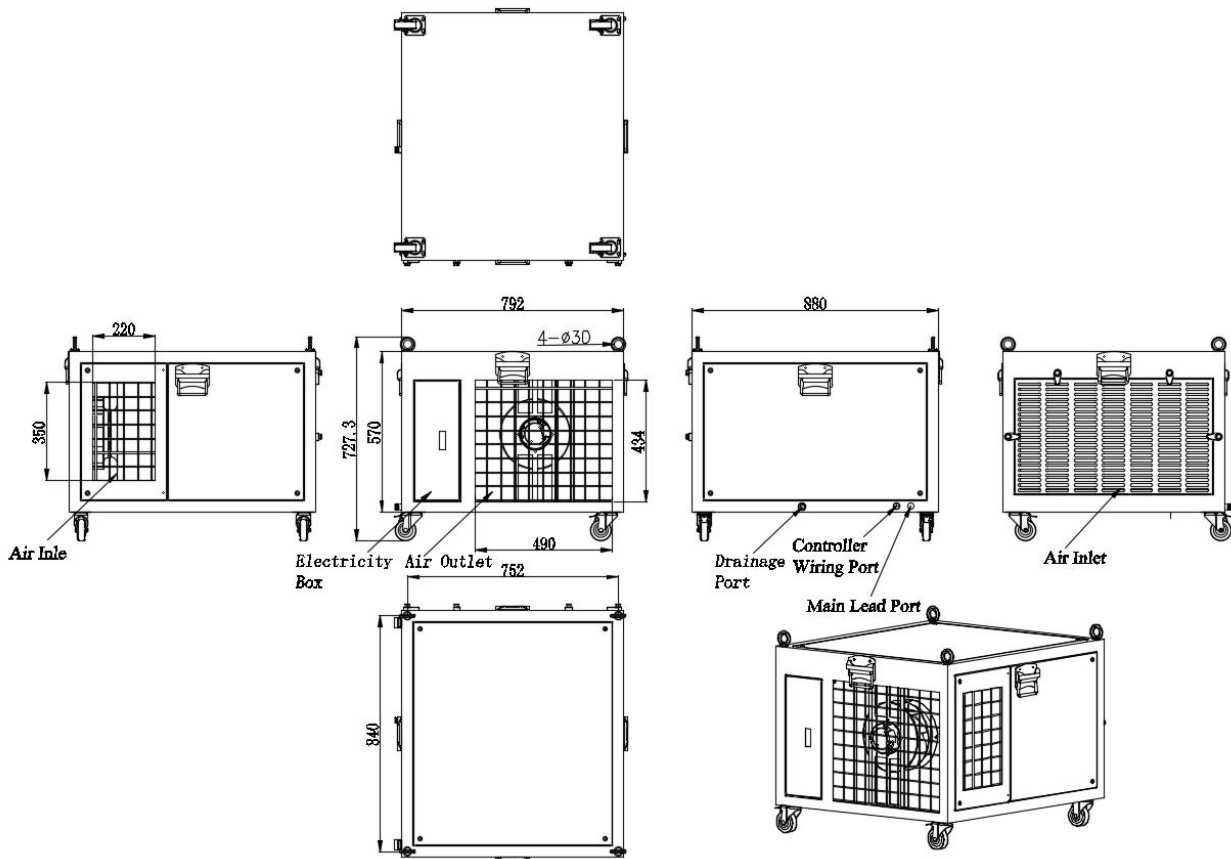



THEPROTECTOR LIMITED PRODUCT WARRANTY

Please take the time to read through our Standard Terms and Conditions of the THEPROTECTOR Limited Product Warranty.

How Long Does The Coverage Last?

The product warranty becomes effective from the date of purchase by the purchaser. Coverage terminates if you sell or otherwise transfer the product. The repair of your product under warranty will not extend the period of the warranty. Each part has its own warranty. Please check the warranty list before you place an order.

How Do You Get Service?

Products are to be returned to THEPROTECTOR Tech Support Center under your express account. Address: 10725 Capital St. Oak Park. MI +1 248-542-1831

What is Covered?

Normal wear and tear. We will repair or replace your product if your product is found, within the warranty period, to be defective due to defective materials or workmanship existing at the time of purchase. If any part is no longer available or out of manufacture, THEPROTECTOR will replace it with a functionally-equivalent replacement part.

What is Not Covered?

THEPROTECTOR shall NOT be liable for costs of repair or replacement of a product incurred as a result of:

1. Accidental damage, faults caused by negligent use or care, neglect, careless operation or handling of the product which is not in accordance with the THEPROTECTOR Instruction Manuals.
2. Use of the parts not assembled or installed in accordance with the instructions of THEPROTECTOR.
3. Use of parts or accessories other than those produced or recommended by THEPROTECTOR.
4. External sources such as transit damage or weather.
5. Repairs or alterations carried out by parties other than THEPROTECTOR or its authorized agents.
6. Serial numbers defaced or missing.

THEPROTECTOR warrants the mechanical and electronic components of all THEPROTECTOR series to be free of defects in material and workmanship if used under normal operating conditions for a period from the original date of purchase. If the product shows any defects within this period and that defect is not due to user error or improper use THEPROTECTOR shall, at its discretion, either replace or repair the product using suitable new or refurbished parts. In case THEPROTECTOR decides to replace the entire product, this limited warranty shall apply to the replacement product for the remaining initial warranty period.

THEPROTECTOR DISCLAIMS ANY AND ALL LIABILITY, INCLUDING ANY EXPRESS OR IMPLIED WARRANTIES, WHETHER ORAL OR WRITTEN, FOR SUCH THIRD PARTY HARDWARE. THE CUSTOMER ACKNOWLEDGES THAT THEPROTECTOR HAS MADE ITS BEST EFFORTS TO MATCH ITS PRODUCTS TO WORK WITH THIRD PARTY HARDWARE OR THE ABILITY TO CONNECT TO AND CONTROL THIRD PARTY HARDWARE FOR THE CUSTOMER'S INTENDED PURPOSE. THEPROTECTOR ADDITIONALLY AND SPECIFICALLY DISCLAIMS ANY AND ALL LIABILITY FOR CHANGES, ADDITIONS OR UPDATES IN ANY WAY TO A THIRD PARTY MANUFACTURES PRODUCTS.

